

信昌電子陶瓷股份有限公司
Prosperity Dielectrics Co., Ltd.

No.566-1, Gaoshi Rd., Lujhu, Yangmei Dist., Taoyuan City 32668, Taiwan, R.O.C.
Tel. : +886-3-4753355 Fax : +886-3-4854959

<https://www.pdc.com.tw/>

SPECIFICATION FOR APPROVAL

DATE :

CUSTOMER : _____

PART NAME : Auto Grade Anti-Sulfur Thin Film Precision Chip Resistor

CUSTOMER'S DWG. NO. : _____

CUSTOMER'S PART NO. : _____

PDC PART NO. : **FAF-MH SERIES APPROVED**

DESCRIPTION. : _____

	ACTION	"V"	CUSTOMER'S SIGNATURE	NOTE
RESULT				
FULL APPROVED				
CONDITIONAL APPROVED				
REJECTED				

OUR ACTION	SIGNATURE
PREPARED By	<i>Jenny Tseng</i>
CHECKED By	<i>Tony Chou</i>
APPROVED By	<i>Byron Tsai</i>

CUSTOMER SIGNATURE FOR ACCEPTANCE

Contents.

Descriptions	Pages
01. Features	2
02. Applications	2
03. Dimension and construction	2
04. Power Derating Curve	3
05. Rating	3
06. Part Number	4
07. Marking / Soldering / Surge	5
08. Reliability Performance	10
09. Packing Information	11
10. Storage / Handling	12

1. Features

- SMD TaN thin film resistor
- Special passivation layer on resistive film
- AEC-Q200 qualified
- Products with lead free terminations meet RoHS requirements
- Sulfur resistant (per ASTM B809-95 humid vapor test)
- AEC-Q200 ESD rated class 1C
- +/-0.02% is upon the customer request.
- Laser trimmed to any value
- 100% visual inspection

2. Applications

- Automotive electronics, Medical equipment
- Measuring instrument, Industrial Equipment

3. Dimension and Construction

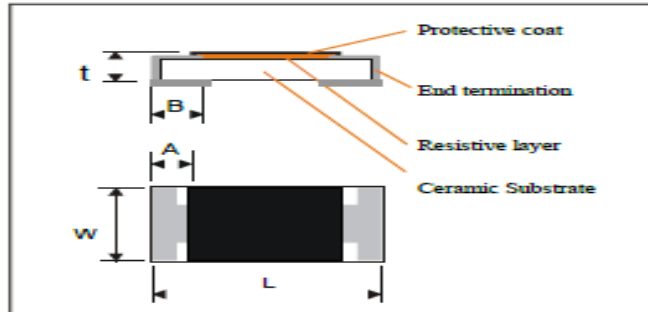

unit:mm

FAF-MH	1206	0805	0603	0402
L	3.00 ± 0.10	2.00 ± 0.10	1.55 ± 0.10	1.00 ± 0.10
W	1.50 ± 0.10	1.25 ± 0.10	0.80 ± 0.10	0.50 ± 0.05
A	0.40 ± 0.20	0.35 ± 0.20	0.30 ± 0.20	0.25 ± 0.15
B	0.40 ± 0.20	0.40 ± 0.20	0.30 ± 0.15	0.30 ± 0.10
t	0.60 ± 0.15	0.50 ± 0.15	0.45 ± 0.15	0.30 ± 0.10



4. Power Derating Curve

The power that the resistor can dissipate depends on the operating temperature.

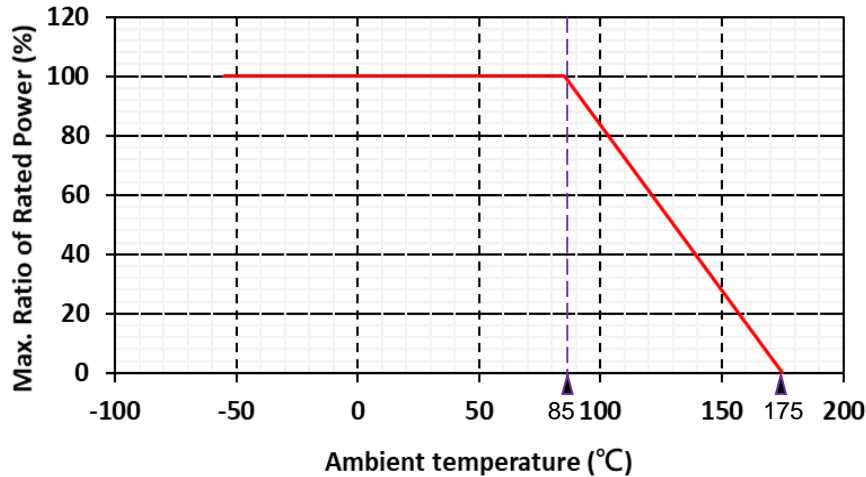

5. Rating

5.1 Standard Power, TCR 50/25 ppm

Item	Standard Power		
Series No.	FAF06...MH	FAF05...MH	FAF03...MH
Size code	1206 (3216)	0805 (2012)	0603 (1608)
Resistance Tolerance	±1%, ±0.5%, ±0.25%, ±0.1%, ±0.05%		
Resistance Range	10Ω ~ 1MΩ	10Ω ~ 350KΩ	40Ω ~ 130KΩ
TCR (ppm/°C)	P:±50 / Q:±25		
Max. dissipation at T _{amb} =85°C	0.25W (D)	0.125W (C)	0.10W (B)
Max. Operation Voltage (DC or RMS)	200V	100V	75V
Max. Overload Voltage (DC or RMS)	400V	200V	150V
Operating Temperature Range	- 55~ +175°C		

Note:

1. This is the maximum voltage that may be continuously supplied to the resistor element, see "IEC publication 60115-8"
2. Max. Operation Voltage: So called RCWV (Rated Continuous Working Voltage) is determined by or Max. RCWV listed above, whichever is lower.



FAF_MH series. (AEC-Q200)

Thin-film Lead Free

High Precision Chip Resistors

5.2 Power type, TCR 50/25/15/10 ppm

Item	Power Type			
Series No.	FAF06...MH	FAF05...MH	FAF03...MH	FAF02...MH
Size code	1206 (3216)	0805 (2012)	0603 (1608)	0402 (1005)
Resistance Tolerance	±1%, ±0.5%, ±0.25%, ±0.1%, ±0.05%			
Resistance Range	10Ω ~ 1MΩ	10Ω ~ 350KΩ	40Ω ~ 130KΩ	40Ω ~ 35KΩ
TCR (ppm/°C)	P:±50 / Q:±25 / S:±15 / V:±10			
Max. dissipation at T _{amb} =85°C	0.40W (R)	0.20W (S)	0.15W (U)	0.0625W (A)
Max. Operation Voltage (DC or RMS)	200V	100V	75V	50V
Max. Overload Voltage (DC or RMS)	400V	200V	150V	100V
Operating Temperature Range	-55~ +175°C			

Note:

1. This is the maximum voltage that may be continuously supplied to the resistor element, see "IEC publication 60115-8"
2. Max. Operation Voltage: So called RCWV (Rated Continuous Working Voltage) is determined by or Max. RCWV listed above, whichever is lower.

6. Part Number

Type	Size	Tolerance	Packing	Watt (W)	R Code	TCR	Special Code
FAF	02 0402	A ±0.05%	Paper Tape	A 0.0625	XXXX 4 digits	V 10	MH Meet AEC-Q200. Anti-Sulfur.
	03 0603	B ±0.1%	0402,0603	B 0.10		S 15	
	05 0805	C ±0.25%	0805,1206	C 0.125		Q 25	
	06 1206	D ±0.5%	I 5Kpcs	U 0.15		P 50	
		E ±1%	V 10Kpcs	S 0.20			
						D 0.25	
			R 0.40				

Example :

FAF02FVA1001QMH

→0402 size, ±1%, paper tape, 0.0625W, 1KΩ, 25ppm, Aec-Q200.

FAF05BTC4991PMH

→0805 size, ±0.1%, paper tape, 0.125W, 4.99KΩ, 50ppm, Aec-Q200.



FAF_MH series. (AEC-Q200) Thin-film Lead Free High Precision Chip Resistors

7. Marking/Soldering/Pulse

No marking for 0402 size

3 digits marking for 0603 size

Nominal resistance	Description																																																							
1.E24 series	2 significant digits followed by No. of zeros . Example <table border="1"> <thead> <tr> <th>RESISTANCE</th> <th>4.7Ω</th> <th>47Ω</th> <th>470Ω</th> <th>4K70</th> <th>47K0</th> <th>470K</th> <th>4M70</th> </tr> </thead> <tbody> <tr> <td>3 digits marking</td> <td>4R7</td> <td>470</td> <td>471</td> <td>472</td> <td>473</td> <td>474</td> <td>475</td> </tr> </tbody> </table>	RESISTANCE	4.7Ω	47Ω	470Ω	4K70	47K0	470K	4M70	3 digits marking	4R7	470	471	472	473	474	475																																							
RESISTANCE	4.7Ω	47Ω	470Ω	4K70	47K0	470K	4M70																																																	
3 digits marking	4R7	470	471	472	473	474	475																																																	
2.E96 series	The 1st two digit codes are referring to the CODE on the table, the 3rd code is the index of resistance value. Repeat values between E24 and E96 series, whose marking are based on the E96 CODE table. <table border="1"> <thead> <tr> <th>Code</th> <th>Z</th> <th>Y</th> <th>X</th> <th>A</th> <th>B</th> <th>C</th> <th>D</th> <th>E</th> <th>F</th> <th>G</th> </tr> <tr> <th>Multiplier</th> <th>10⁻³</th> <th>10⁻²</th> <th>10⁻¹</th> <th>10⁰</th> <th>10¹</th> <th>10²</th> <th>10³</th> <th>10⁴</th> <th>10⁵</th> <th>10⁶</th> </tr> </thead> <tbody> <tr> <td colspan="11">Example</td> </tr> <tr> <td>RESISTANCE</td> <td>1.78Ω</td> <td>17.8Ω</td> <td>178Ω</td> <td>1K78</td> <td>17K8</td> <td>178K</td> <td>1M78</td> <td colspan="3"></td> </tr> <tr> <td>3 digits marking</td> <td>25Y</td> <td>25X</td> <td>25A</td> <td>25B</td> <td>25C</td> <td>25D</td> <td>25E</td> <td colspan="3"></td> </tr> </tbody> </table>	Code	Z	Y	X	A	B	C	D	E	F	G	Multiplier	10 ⁻³	10 ⁻²	10 ⁻¹	10 ⁰	10 ¹	10 ²	10 ³	10 ⁴	10 ⁵	10 ⁶	Example											RESISTANCE	1.78Ω	17.8Ω	178Ω	1K78	17K8	178K	1M78				3 digits marking	25Y	25X	25A	25B	25C	25D	25E			
Code	Z	Y	X	A	B	C	D	E	F	G																																														
Multiplier	10 ⁻³	10 ⁻²	10 ⁻¹	10 ⁰	10 ¹	10 ²	10 ³	10 ⁴	10 ⁵	10 ⁶																																														
Example																																																								
RESISTANCE	1.78Ω	17.8Ω	178Ω	1K78	17K8	178K	1M78																																																	
3 digits marking	25Y	25X	25A	25B	25C	25D	25E																																																	
3. Remark	There is no marking for the items not under E24 and E96 series.																																																							

E96 CODE table:

CODE	R value	CODE	R-value	CODE	R-Value	CODE	R-value	CODE	R-value	CODE	R-value	CODE	R-value	CODE	R-value
01	100	13	133	25	178	37	237	49	316	61	422	73	562	85	750
02	102	14	137	26	182	38	243	50	324	62	432	74	576	86	768
03	105	15	140	27	187	39	249	51	332	63	442	75	590	87	787
04	107	16	143	28	191	40	255	52	340	64	453	76	604	88	806
05	110	17	147	29	196	41	261	53	348	65	464	77	619	89	825
06	113	18	150	30	200	42	267	54	357	66	475	78	634	90	845
07	115	19	154	31	205	43	274	55	365	67	487	79	649	91	866
08	118	20	158	32	210	44	280	56	374	68	499	80	665	92	887
09	121	21	162	33	215	45	287	57	383	69	511	81	681	93	909
10	124	22	165	34	221	46	294	58	392	70	523	82	698	94	931
11	127	23	169	35	226	47	301	59	402	71	536	83	715	95	953
12	130	24	174	36	232	48	309	60	412	72	549	84	732	96	976

4 digits marking for 0805/1206 size:

Each resistor is marked with a four digits code on the protective coating to designate the nominal resistance value.

The first 3 digits are significant, and the fourth digit indicates the number of multiple to follow. For non E24/E96 series, no marking is applied.

Example

RESISTANCE	10Ω	47Ω	470Ω	6800Ω	47000Ω	470000Ω	1000000Ω
4 digits marking	10R0	47R0	4700	6801	4702	4703	1004



FAF_MH series. (AEC-Q200) Thin-film Lead Free High Precision Chip Resistors

SOLDERING CONDITION

The robust construction of chip resistors allows them to be completely immersed in a solder bath of 260°C for 10 seconds. Therefore, it is possible to mount Surface Mount Resistors on one side of a PCB and other discrete components on the reverse (mixed PCBs). Surface Mount Resistors are tested for solderability at 235°C during 2 seconds within lead-free solder bath. The test condition for no leaching is 260°C for 30 seconds. Typical examples of soldering profile and condition that provide reliable joints without any damage are given in Fig 1. and Table A.

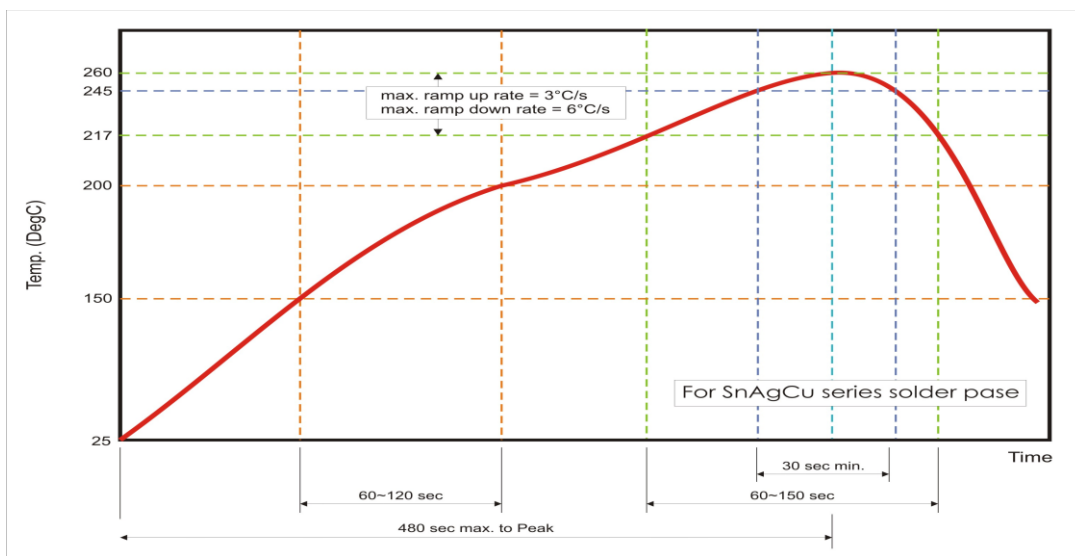

Fig. 1 Infrared soldering profile for Chip Resistors

Table A. Infrared soldering condition for Chip Resistors

Temperature Condition	Exposure Time
Average ramp-up rate (217°C to 260°C)	Less than 3°C/second
Between 150 and 200°C	Between 60-120 seconds
> 217°C	Between 60-150 seconds
Peak Temperature	260°C +0/-5°C
Time within 245°C	Min. 30 seconds
Ramp-down rate (Peak to 217°C)	Less than 6°C/second
Time from 25°C to Peak	No greater than 480 seconds



Recommend Solder Pad Dimensions (mm)

Type	W	D	L
FAF02	0.60	0.50	1.50
FAF03	0.90	1.00	3.00
FAF05	1.30	1.15	3.50
FAF06	1.80	1.30	4.70

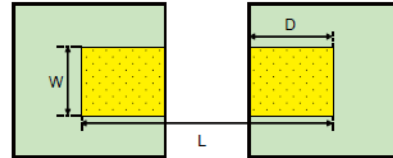

PULSE LOAD PERFORMANCE

Single Pulse

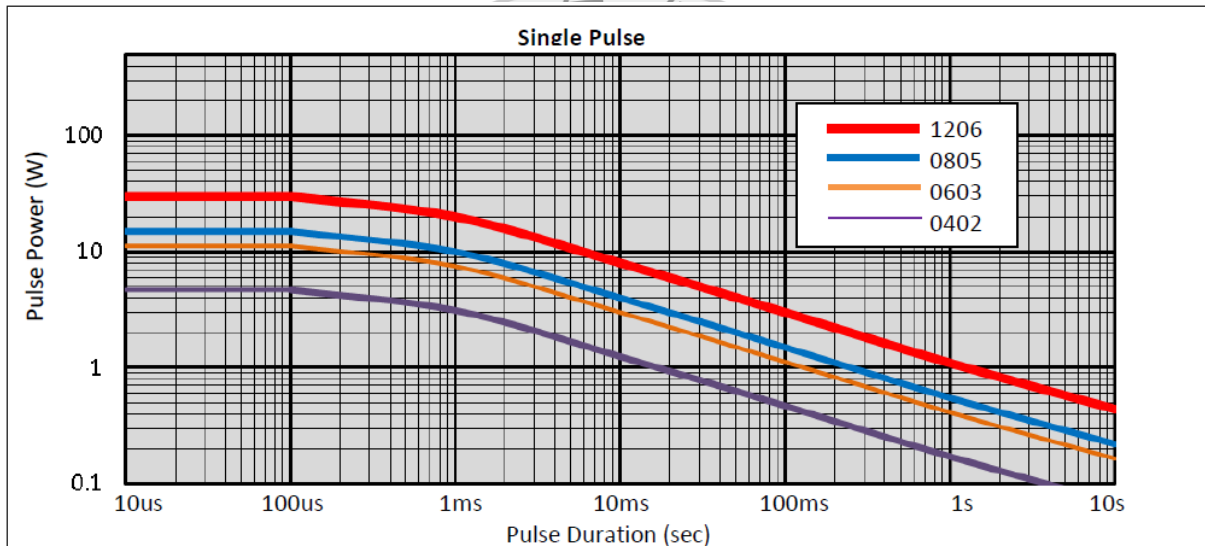

Single Pulse for $R \geq 10 \Omega$

50 rectangular pulse amplitudes are applied to the component at intervals of 60seconds, permissible the resistance to be varied by $\pm (0.5\% R + 0.01\Omega)$.

Continue Pulse

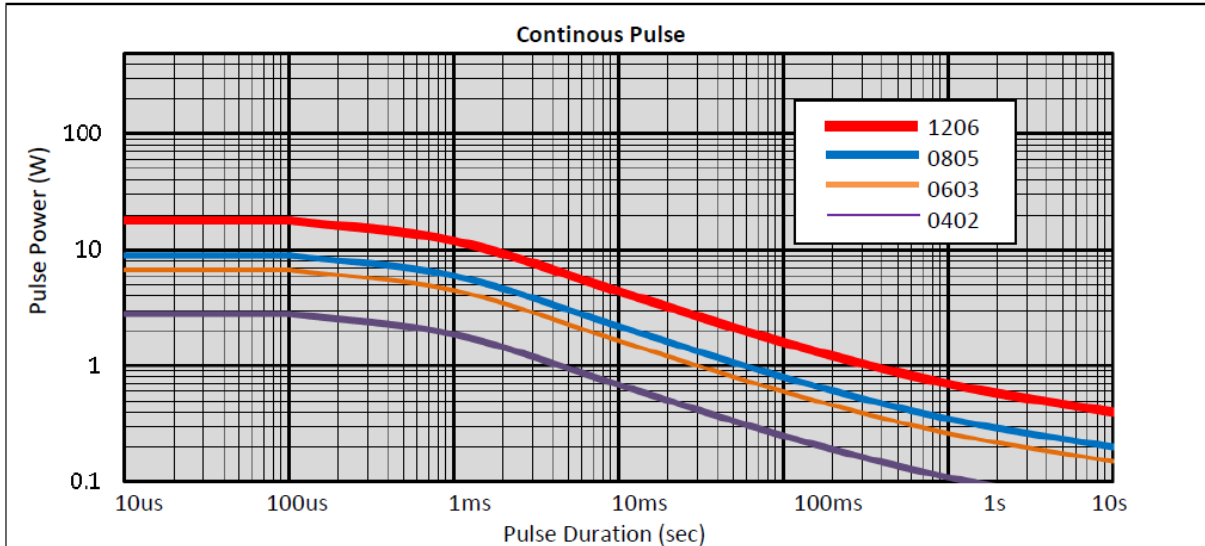

Continuous Pulse for $R \geq 10 \Omega$

Continuous load is a pulse period generated by the repetitive rectangular pulse amplitude, the applied power dissipation is at a rated power of 70 ° C.

Permissible the resistance to be varied by $\pm (0.5\% R + 0.01\Omega)$.

Pulse Voltage

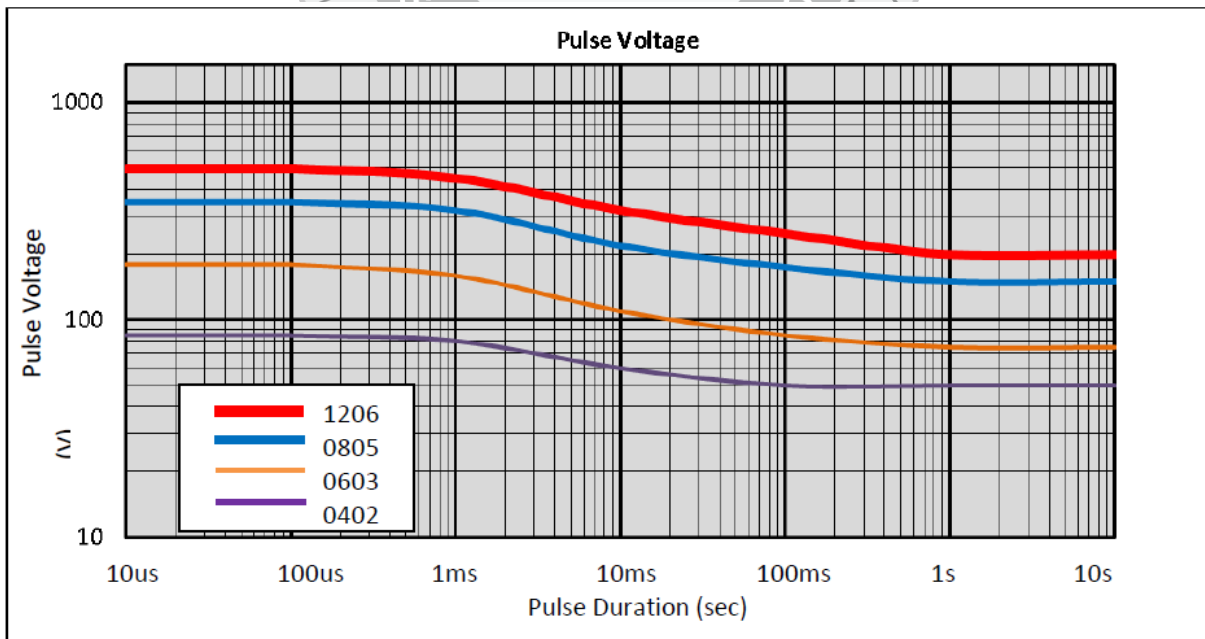

FAF_MH series. (AEC-Q200) Thin-film Lead Free High Precision Chip Resistors

Pulse Surge Overload : 1.2 / 50us Pulse

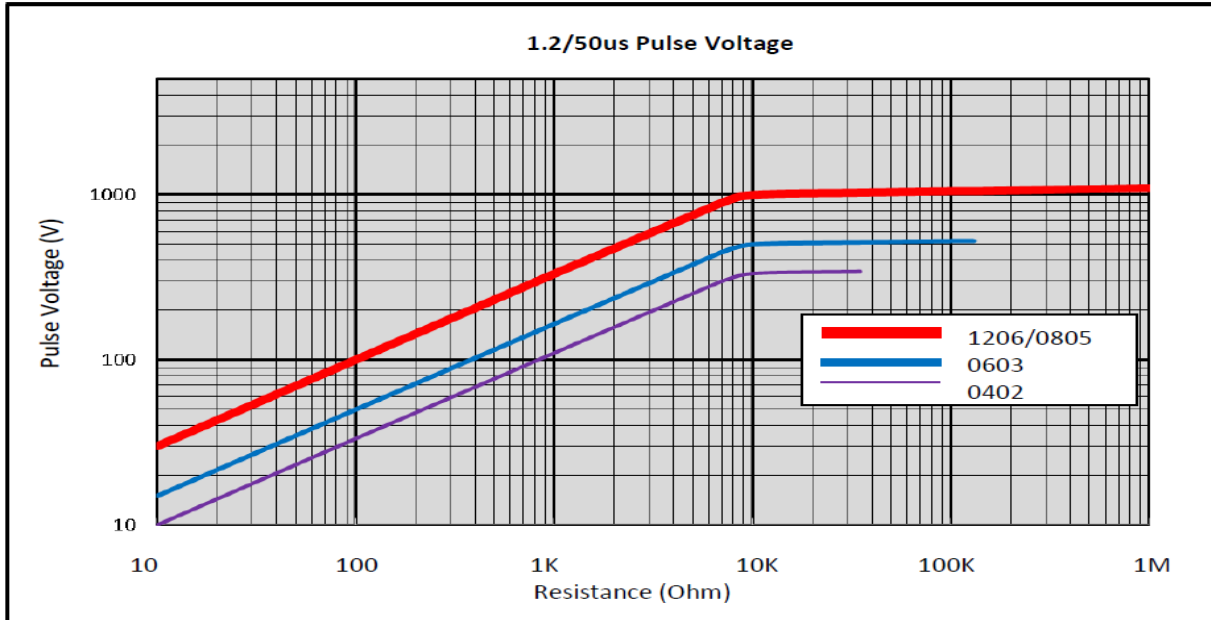

According to IEC 60115-1 4.27 1.2 / 50us use 5 pulses at 12sec intervals pulse shapes test resistor, permissible the resistance to be varied by $\pm (0.5\% R + 0.01\Omega)$.

Pulse Surge Overload : 10 / 700us Pulse

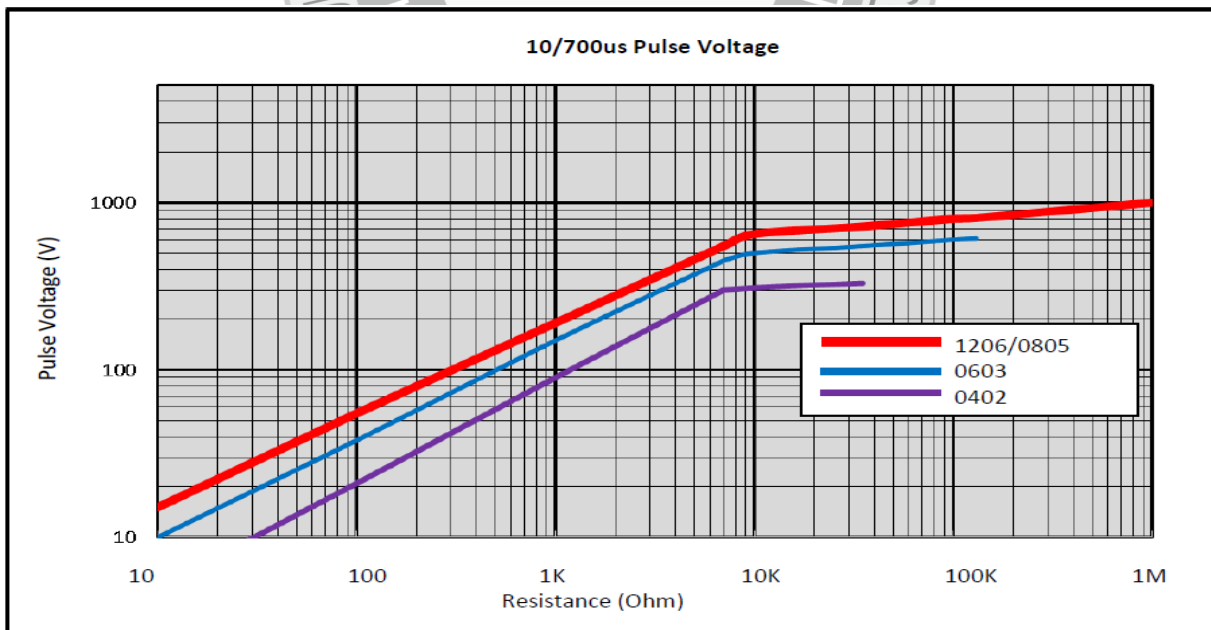

According to IEC 60115-1 4.27 10 / 700us use 10 pulses at 60sec intervals pulse shapes test resistor, permissible the resistance to be varied by $\pm (0.5\% R + 0.01\Omega)$.



8. Reliability Performance (AEC-Q200)

TEST	PROCEDURE	REQUIREMENT
Electrical Characteristics IEC 60115-1 4.8	- DC resistance values measurement - Temperature Coefficient of Resistance (T.C.R) Natural resistance change per change in degree centigrade. $\frac{R_2 - R_1}{R_1(t_2 - t_1)} \times 10^6 \text{ (ppm/}^\circ\text{C)}$ $t_1 : 20^\circ\text{C} \pm 5^\circ\text{C} / -1^\circ\text{C}$ $R_1 : \text{Resistance at reference temperature (20}^\circ\text{C} \pm 5^\circ\text{C} / -1^\circ\text{C)}$ $R_2 : \text{Resistance at test temperature (-55}^\circ\text{C or +125}^\circ\text{C)}$	Within the specified tolerance
Short time overload (S.T.O.L) IEC60115-1 4.13	Permanent resistance change after a 5second application of a voltage 2.5 times RCWV or the maximum overload voltage specified in the above list, whichever is less.	$\Delta R/R$ max. $\pm(0.1\%+0.02\Omega)$
Resistance to soldering heat(R.S.H) AEC-Q200-15	Un-mounted chips completely immersed for 10 ± 1 second in a SAC solder bath at $260^\circ\text{C} \pm 5^\circ\text{C}$	no visible damage $\Delta R/R$ max. $\pm(0.1\%+0.02\Omega)$
Solderability IEC 60068-2-58	Un-mounted chips completely immersed for 2 ± 0.5 second in a SAC solder bath at $235^\circ\text{C} \pm 5^\circ\text{C}$	good tinning (>95% covered) no visible damage
Temperature cycling JESD22 method JA-104	1000 cycles, $-55^\circ\text{C} \sim +125^\circ\text{C}$, dwell time 5~10min	$\Delta R/R$ max. $\pm(0.1\%+0.02\Omega)$
	1000 cycles, $-55^\circ\text{C} \sim +155^\circ\text{C}$, dwell time 5~10min	$\Delta R/R$ max. $\pm(0.2\%+0.02\Omega)$
Bias Humidity AEC-Q200-7	1000 +48/-0 hours, loaded with 10% rated power in humidity chamber controller at $+85^\circ\text{C} / 85\%RH$	$\Delta R/R$ max. $\pm(0.1\%+0.02\Omega)$
High Temperature Operating Life MIL-STD-202 Method 108	1000 +48/-0 hours, loaded with RCWV or V_{max} in chamber controller $85 \pm 2^\circ\text{C}$, 1.5 hours on and 0.5 hours off	$\Delta R/R$ max. $\pm(0.1\%+0.02\Omega)$
High Temperature Exposure AEC-Q200-3	1000 hours at 125°C , un-powered	$\Delta R/R$ max. $\pm(0.1\%+0.02\Omega)$
	1000 hours at 155°C , un-powered	$\Delta R/R$ max. $\pm(0.15\%+0.02\Omega)$
	1000 hours at 175°C , un-powered	$\Delta R/R$ max. $\pm(0.30\%+0.02\Omega)$
Moisture Resistance AEC-Q200 -6 MIL-STD-202 Method 106	$65 \pm 2^\circ\text{C}$, 80~100% RH, 10 cycles, 24 hours/ cycle	$\Delta R/R$ max. $\pm(0.1\%+0.02\Omega)$
Mechanical Shock MIL-STD-202 Method 213	1/2 Sine Pulse / 1500g Peak / Velocity 15.4ft/sec	$\Delta R/R$ max. $\pm(0.1\%+0.02\Omega)$
Vibration MIL-STD-202 Method 204	5 g's for 20 min , 12 cycles each of 3 orientations	$\Delta R/R$ max. $\pm(0.1\%+0.02\Omega)$
Terminal strength AEC-Q200-6	1 kg for 60 s	No broken
Board flex AEC-Q200-005	Bending 2mm for 60 sec	$\Delta R/R$ max. $\pm(0.1\%+0.02\Omega)$
Flower of sulfur ASTM-B809-95	$105 \pm 2^\circ\text{C}$, duration 1000hours.	0402 : $\Delta R/R$ max. $\pm(0.2\%+0.02\Omega)$ Others: $\Delta R/R$ max. $\pm(0.1\%+0.02\Omega)$



FAF_MH series. (AEC-Q200) Thin-film Lead Free High Precision Chip Resistors

ESD AEC-Q200-002	0402 : 500V 0603 : 1000V 0805 : 1500V 1206 : 2000V	$\Delta R/R$ max. $\pm(0.5\%+0.02\Omega)$ No visible damage
---------------------	---	--

9. PACKAGING

Paper Tape specifications (unit :mm)

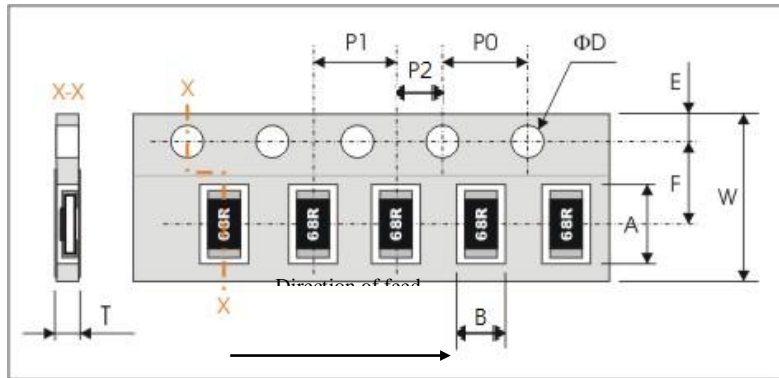

Series No.	A	B	W	F	E
FAF06...MH	3.60±0.20	2.00±0.20	8.00±0.30	3.50±0.20	1.75±0.10
FAF05...MH	2.40±0.20	1.65±0.20	8.00±0.30	3.50±0.20	1.75±0.10
FAF03...MH	1.90±0.20	1.10±0.20	8.00±0.30	3.50±0.20	1.75±0.10
FAF02...MH	1.20±0.10	0.7±0.10	8.00±0.30	3.50±0.05	1.75±0.10

Series No.	P1	P0	P2	ΦD	T
FAF06...MH	4.00±0.10	4.00±0.10	2.00±0.10	$\Phi 1.50^{+0.1}_{-0.0}$	Max. 1.0
FAF05...MH	4.00±0.10	4.00±0.10	2.00±0.10	$\Phi 1.50^{+0.1}_{-0.0}$	Max. 1.0
FAF03...MH	4.00±0.10	4.00±0.10	2.00±0.10	$\Phi 1.50^{+0.1}_{-0.0}$	0.65±0.05
FAF02...MH	2.00±0.10	4.00±0.10	2.00±0.10	$\Phi 1.50^{+0.1}_{-0.0}$	0.40±0.05



Reel dimensions

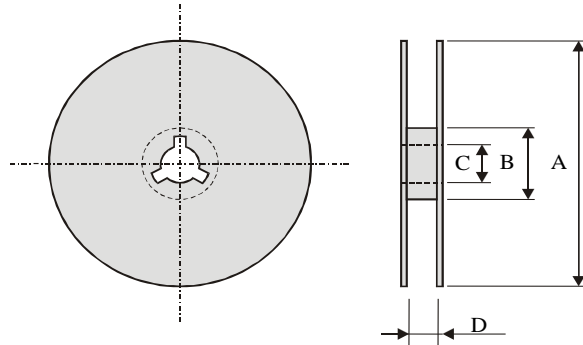

Symbol	A	B	C	D
(unit : mm)	$\Phi 178.0 \pm 2.0$	$\Phi 60.0 \pm 1.0$	13.0 ± 0.2	9.0 ± 0.5

Taping quantity

- Chip resistors 5,000 pcs per reel (0603, 0805, 1206)
- Chip resistors 10,000 pcs per reel (0402)

10. Storage & Handling

... Products are recommended to be used up within one year as ensured shelf life.

Check solder ability in case shelf life extension is needed.

... To store products with following condition:

Temperature: 5 to 40°C ; Humidity: 20 to 70% relative humidity.

Precaution for use :

The AEC-Q200 series resistors is mainly used on general automotive equipment without safety considerations.

Please contact our company in advanced if you intend to use resistor for designing the equipment which may damage itself and the safety of third party. If necessary, please consider to add the protect circuit in devising process and obtaining fully safety evaluation. The contents of the acknowledgment is only used for our parent company, marketing subsidiaries and official marketing agents who purchase our products. Not applicable for the other nonofficial channels.

※ All product specification and data are subject to change without notice.

